



News for 06/17/08

Sneak Peek at the E-Jet

dAMBEST does it again and continues to lead the way in innovation!

The patent pending dAM E-Jet replaces both the float bowl and the main jet. It is controlled by the ECU and can be programmed for multi-fuel mapping. Without a float and needle fuel delivery is unaffected by acceleration forces. You could drive your car upside down!

Here's a sneak peek at the CAD drawings. Stay tuned for photos of a prototype.

John

PS: If anybody has a copy of my 1992 Superflow Presentation on VHS, please contact me.

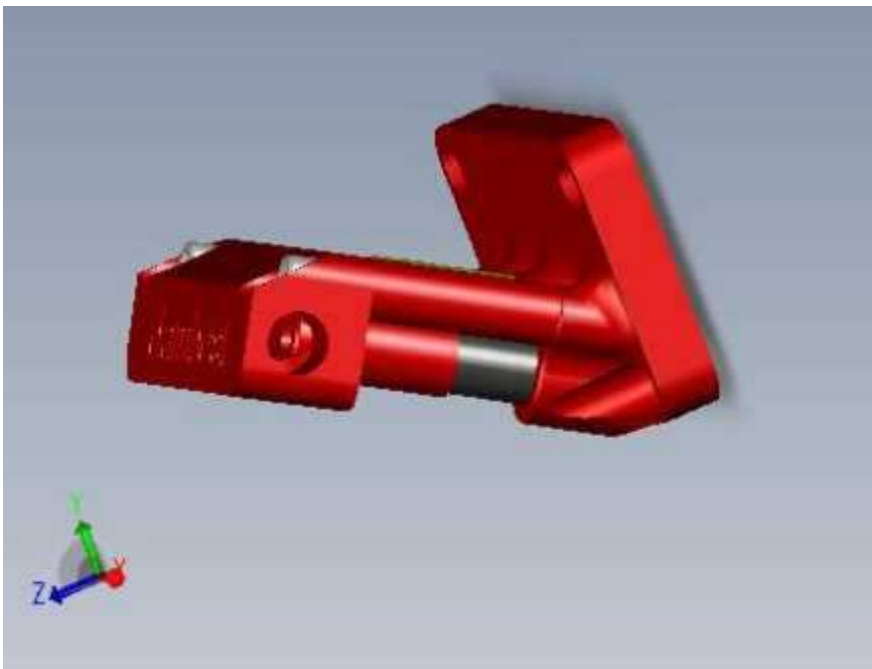

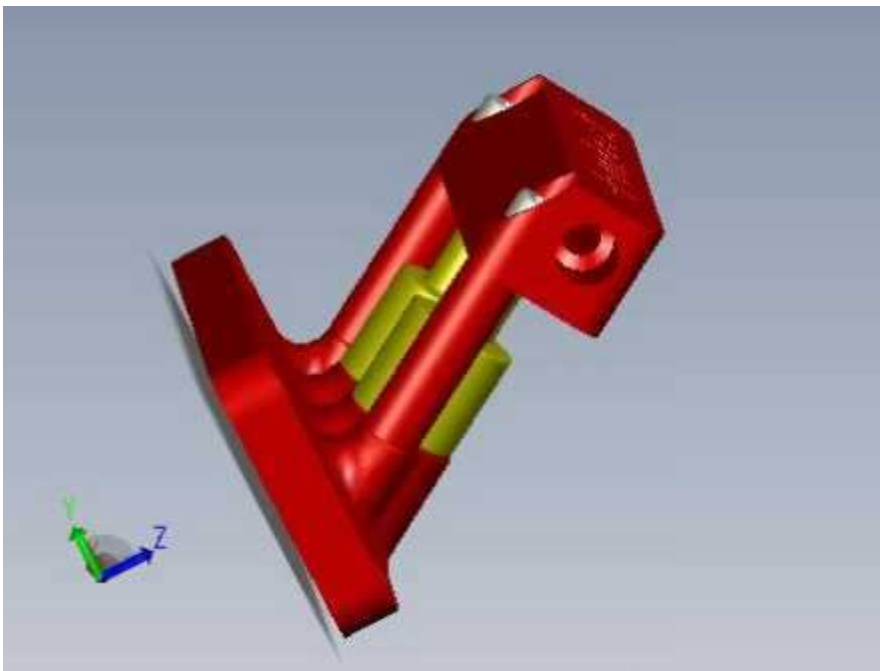
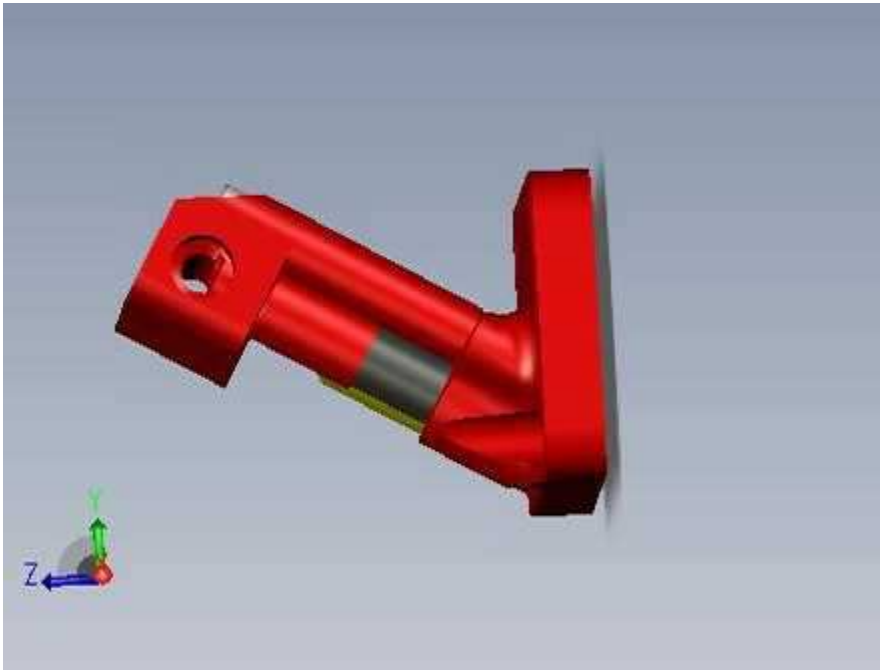

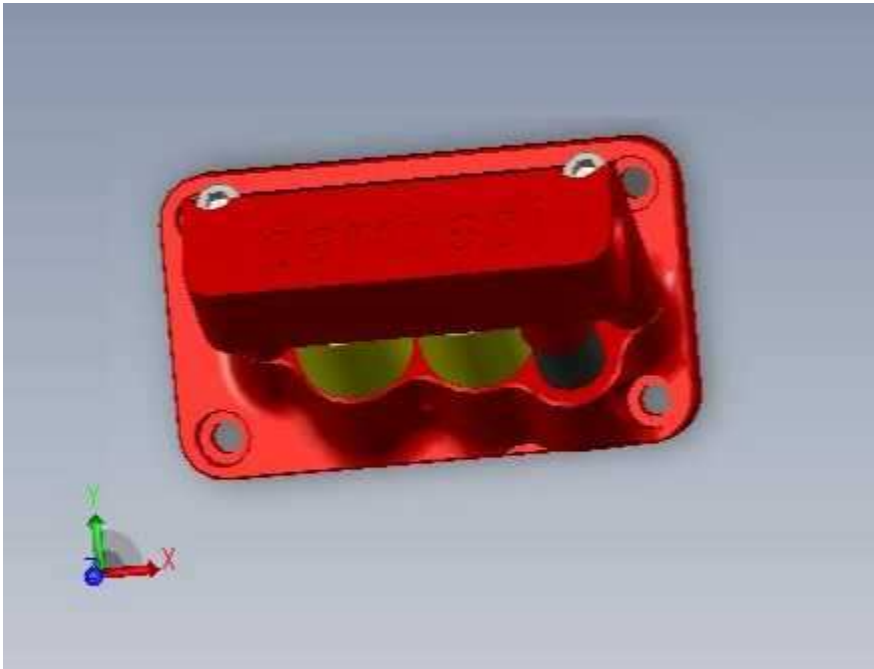

Visit dambest.com.

If you do not wish to receive this News Letter, just reply with REMOVE.
Please quote or forward the complete News Letter to help us remove the correct address.